

## Arc Welding Robot

# ARC12-2000

ARC12-2000 is a medium payloads robot.  
Maxium payload 12 kg with maxium reach 2025 mm.

### Highlights

Thanks to the large and hollow design, the cable can be routed in a hollow way, effectively improving the service life of the cable, and the posture change in a narrow space is more flexible;  
High-rigid gearbox with strong impact resistance helps customers challenge various application scenarios;  
Thanks to the high stiffness transmission design and advanced trajectory algorithm, the improved robot accuracy performance helps customers to face variety of application scenarios.

### Applications

It can be used in Arc welding applications

### Industries

Suitable for metal parts, auto parts, steel structure and other industries.



## EFORT

### SPECIFICATIONS

<b>Model</b>	ARC12-2000	
<b>Type</b>	Articulated	
<b>Controlled axes</b>	6 Axes	
<b>Max. payload on wrist</b>	12 kg	
<b>Repeatability</b>	±0.03 mm	
<b>Robot weight</b>	185 kg	
<b>Reach</b>	2025 mm	
<b>Robot IP grade</b>	IP54 / IP67 (Wrist)	
<b>Cabinet IP grade</b>	IP54	
<b>Drive mode</b>	AC servo drive	
<b>Installation</b>	Floor, Upside-down	
<b>Installation enviroment</b>	<b>Ambient temperature</b>	0~45 °C
	<b>Ambient humidity</b>	RH≤80% (No dew nor frost allowed)
	<b>Vibration acceleration</b>	4.9 m/s <sup>2</sup> (<0.5 G)

<b>Allowable load moment at wrist</b>	<b>J4</b>	22 N·m
	<b>J5</b>	22 N·m
	<b>J6</b>	9.8 N·m
<b>Allowable load inertia at wrist</b>	<b>J4</b>	0.65 kg·m <sup>2</sup>
	<b>J5</b>	0.65 kg·m <sup>2</sup>
	<b>J6</b>	0.17 kg·m <sup>2</sup>
<b>Maximum speed</b>	<b>J1</b>	220°/sec
	<b>J2</b>	180°/sec
	<b>J3</b>	210°/sec
	<b>J4</b>	420°/sec
	<b>J5</b>	420°/sec
	<b>J6</b>	700°/sec
<b>Motion range</b>	<b>J1</b>	±170°
	<b>J2</b>	+77°-160°
	<b>J3</b>	+175°-85°
	<b>J4</b>	±190°
	<b>J5</b>	±190°(The connect outside robot body.) ±140°(The connect inside robot body.)
	<b>J6</b>	±450°(The connect outside robot body.) ±220°(The connect inside robot body.)

### OPERATING SPACE

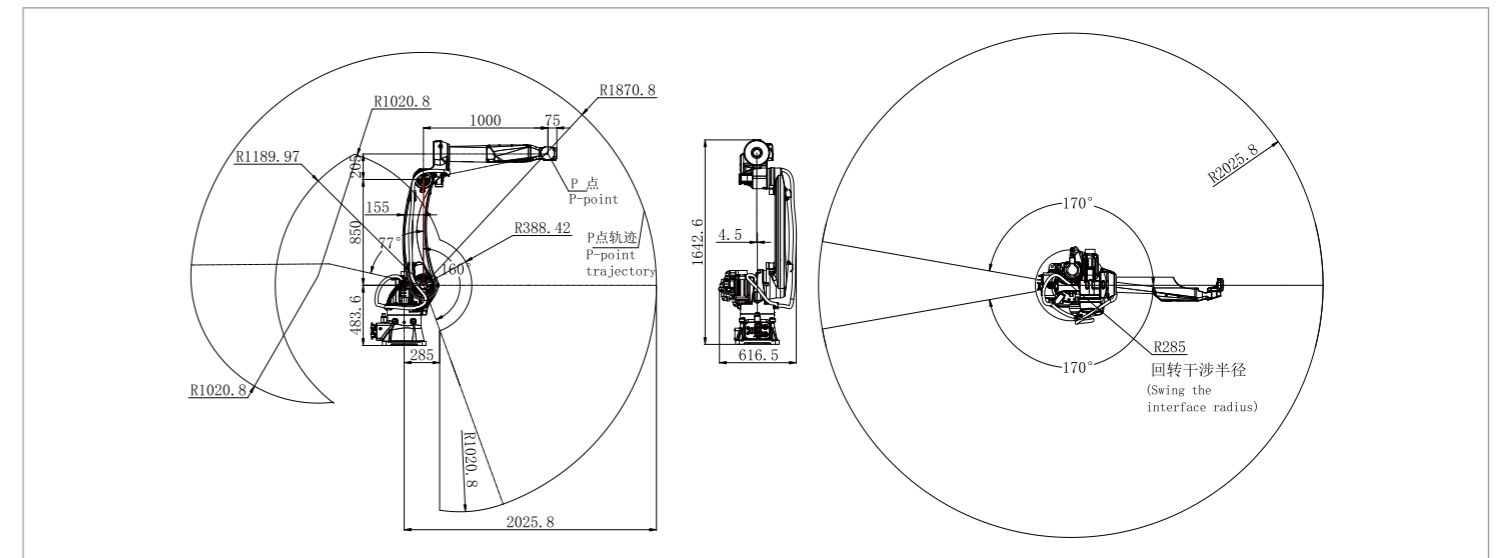

### BASE MOUNTING SIZE

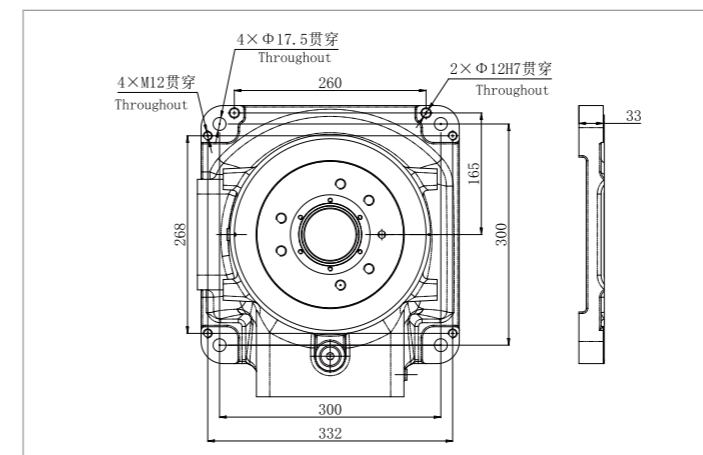

### END FLANGE MOUNTING SIZE

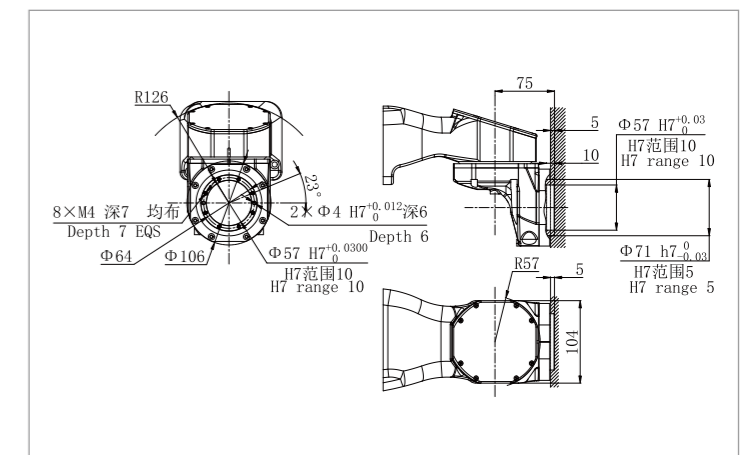

**EFORT Intelligent Equipment Co., Ltd.**  
PHONE: (00 86) 400-052-8877  
ADDRESS: No.96 East Wanchun Road, China(Anhui) Pilot  
Free Trade Zone Wuhu Area, Wuhu, Anhui Province, China  
WWW.EFORT.COM.CN