

ER15-4-1600

EFORT

ER15-4-1600,
Maxium payload 15 kg with maxium reach 1625 mm.

■ **Highlights**

A specific application software of stamping could be integrated, which brings simple programming and operation, and enable customers quickly production launch;
High stiffness robot body design improves the robot dynamic performance and stability in high-speed operation.

■ **Applications**

It can be used in handling operations (machine tending).

■ **Industries**

Suitable for metal parts, logistics and other industries.



SPECIFICATIONS

Model	ER15-4-1600	
Type	Articulated	
Controlled axes	4 Axes	
Max. payload on wrist	15 kg	
Repeatability	±0.07 mm	
Robot weight	180 kg	
Reach	1625 mm	
Robot IP grade	IP54 / IP65 (Wrist)	
Cabinet IP grade	IP20/ IP54 (Optional)	
Installation enviroment	Ambient temperature	0~45 °C
	Ambient humidity	RH≤80% (No dew nor frost allowed)
	Vibration acceleration	4.9 m/s ² (<0.5 G)

Drive mode	AC servo drive	
Installation	Floor	
Allowable load moment at wrist	J4	27.5 N·m
Allowable load inertia at wrist	J4	3.6 kg·m ²
Maximum speed	J1	175°/sec
	J2	165°/sec
	J3	155°/sec
	J4	330°/sec
Motion range	J1	±165°
	J2	+40°-85°
	J3	+100°-70°
	J4	±360°
	J2+J3	-90°≤(J2+J3)≤+15°

OPERATING SPACE

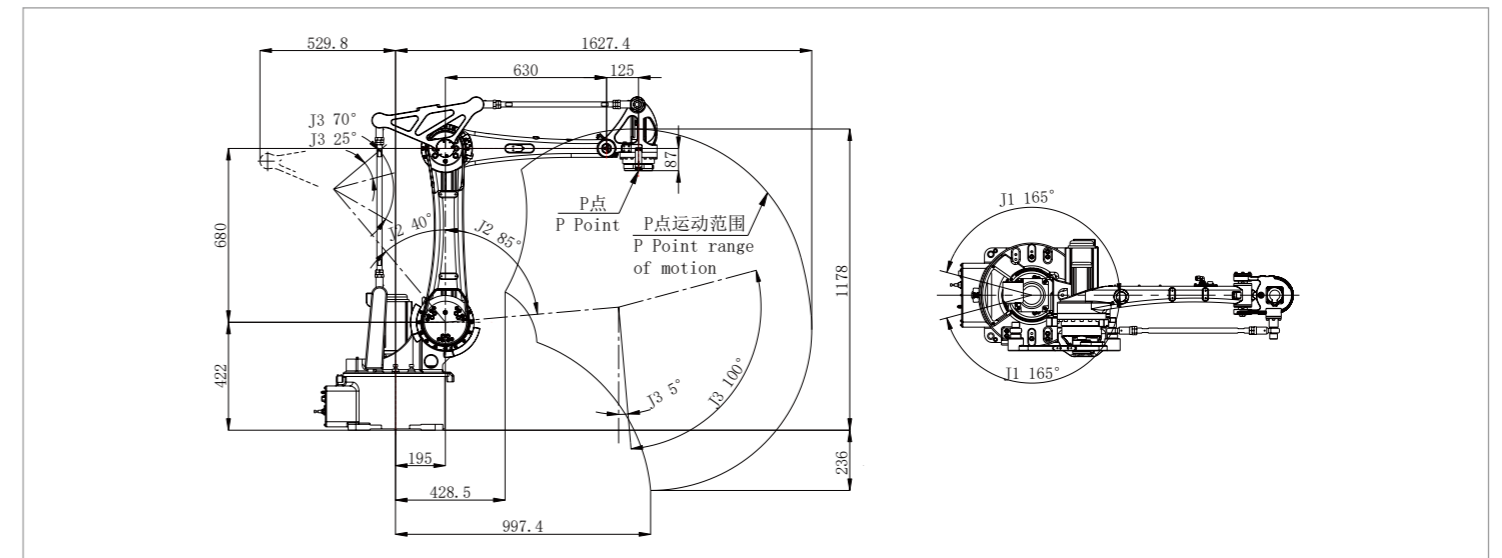

BASE MOUNTING SIZE

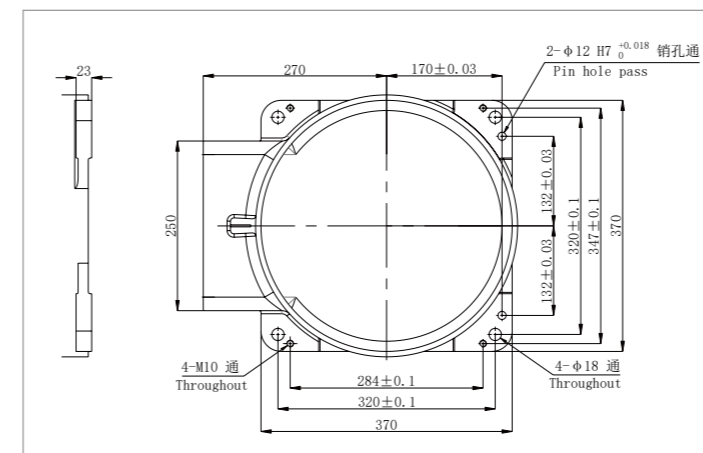

END FLANGE MOUNTING SIZE

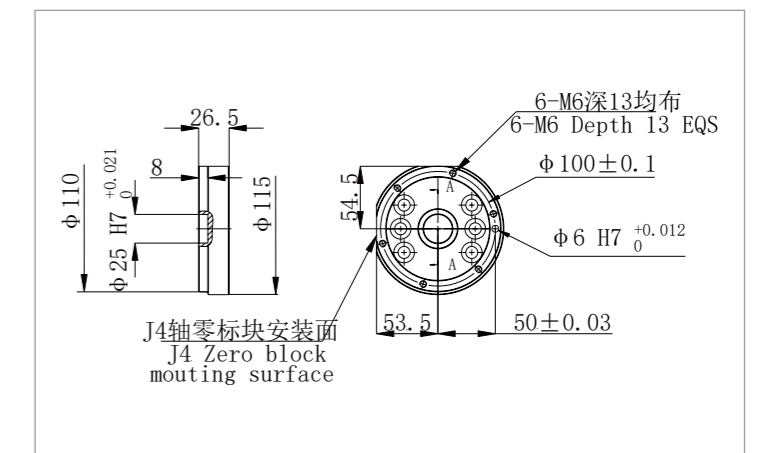

EFORT Intelligent Equipment Co., Ltd.
PHONE: (00 86) 400-052-8877
ADDRESS: No.96 East Wanchun Road, China(Anhui) Pilot
Free Trade Zone Wuhu Area, Wuhu, Anhui Province, China
WWW.EFORT.COM.CN