

ER25-1800

EFORT

ER25-1800,
Maxium payload 25 kg with maxium reach 1850 mm.

Highlights

Thanks to the new design of wrist, inertia and bearing capacity are increased by 25% with wider application scope;
Thanks to the high stiffness transmission design and advanced trajectory algorithm, the improved robot accuracy performance helps customers to face variety of application scenarios;
Lighter weight of the body, 20% less than its predecessor.

Applications

It can be used in handling operations, assembling, grinding, polishing, deburring, etc.

Industries

Suitable for metal parts, photovoltaic, logistics, food and beverage and other industries.



SPECIFICATIONS

| | | |
|--------------------------------|-------------------------------|-----------------------------------|
| Model | ER25-1800 | |
| Type | Articulated | |
| Controlled axes | 6 Axes | |
| Max. payload on wrist | 25 kg | |
| Repeatability | ±0.05 mm | |
| Robot weight | 175 kg | |
| Reach | 1850 mm | |
| Robot IP grade | IP54 / IP67 (Wrist) | |
| Cabinet IP grade | IP20 / IP54 (Optional) | |
| Drive mode | AC servo drive | |
| Installation | Floor, Upside-down, Wall | |
| Installation enviroment | Ambient temperature | 0~45 °C |
| | Ambient humidity | RH≤80% (No dew nor frost allowed) |
| | Vibration acceleration | 4.9 m/s ² (<0.5 G) |

| | | |
|--|-----------|-----------------------|
| Allowable load moment at wrist | J4 | 50 N·m |
| | J5 | 50 N·m |
| | J6 | 30 N·m |
| Allowable load inertia at wrist | J4 | 2.2 kg·m ² |
| | J5 | 2.2 kg·m ² |
| | J6 | 1.5 kg·m ² |
| Maximum speed | J1 | 220°/sec |
| | J2 | 180°/sec |
| | J3 | 200°/sec |
| | J4 | 360°/sec |
| | J5 | 360°/sec |
| | J6 | 410°/sec |
| Motion range | J1 | ±170° |
| | J2 | +77°-160° |
| | J3 | +165°-85° |
| | J4 | ±190° |
| | J5 | ±130° |
| | J6 | ±360° |

OPERATING SPACE

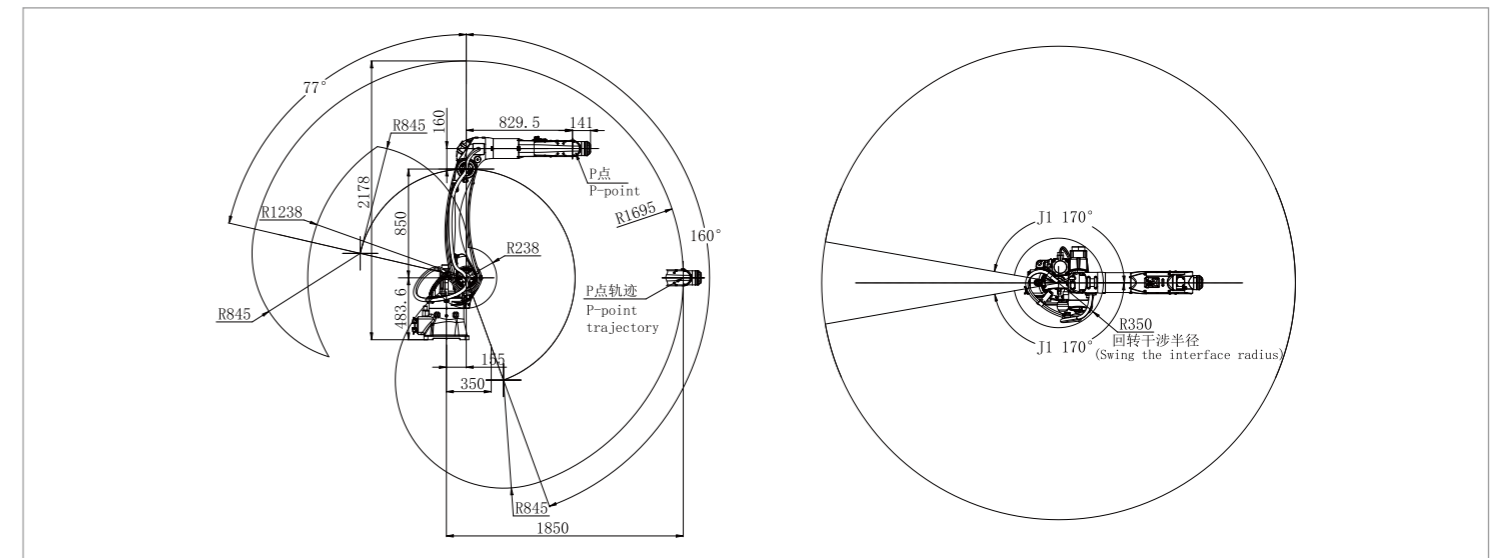

BASE MOUNTING SIZE

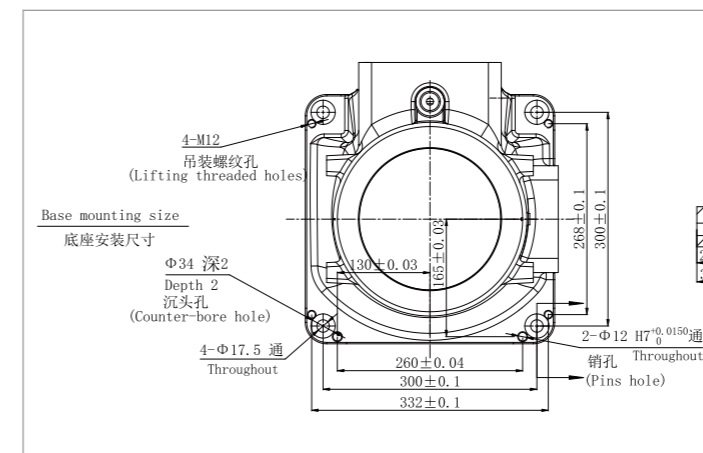

END FLANGE MOUNTING SIZE

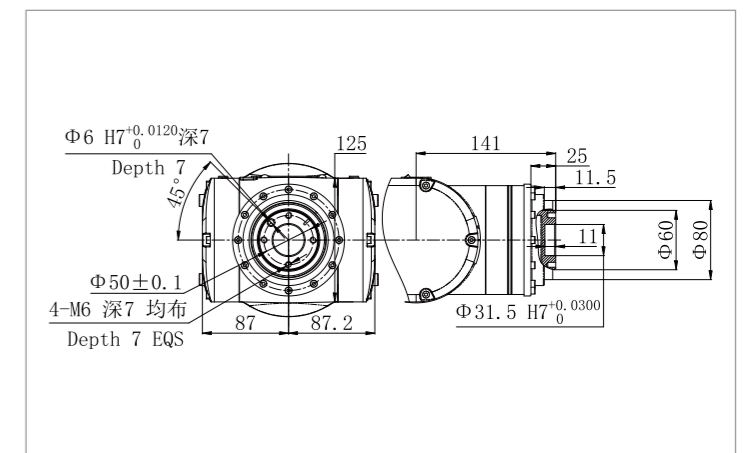

EFORT Intelligent Equipment Co., Ltd.

PHONE: (00 86) 400-052-8877

ADDRESS: No.96 East Wanchun Road, China(Anhui) Pilot

Free Trade Zone Wuhu Area, Wuhu, Anhui Province, China

WWW.EFORT.COM.CN